



REDNET[®]

Cinematic Media

Mexico's Cinematic Media
goes immersive with Focusrite
RedNet Interfaces

**CASE
STUDY**

Focusrite
PRO

New sound design stages made easy with Focusrite RedNet

Words: Clyne Media

Cinematic Media is the only full-service post-production complex in Mexico focused exclusively on episodic television and motion pictures. It has recently unveiled its new Dolby Atmos®-certified mix stages and sound editorial rooms, which have identical setups featuring Focusrite's RedNet range of Dante®-networked audio converters and interfaces.



Keeping it simple

Cinematic Media's six new stages, which are set up for sound design, sound editorial, pre-dubbing, and mixing, each feature a pair of Focusrite RedNet HD32R 32-channel HD Dante network bridges and Red 4Pre 58-In/64-Out Thunderbolt™ 2 and Pro Tools | HD™ compatible audio interfaces (one per room). RedNet AM2 stereo audio monitoring units and RedNet X2P 2x2 Dante® audio interfaces are also available on the stages.

Malvicino Design Group handled the design of the new rooms. Principal Horacio Malvicino said "We tried to replicate the same rooms on all three floors of the building. The only difference is the ceiling height, but as far as the gear, it's all the same. Every floor has its own machine room, which is shared between the two control rooms."

The entire Estudios GGM facility employs the same post-production workflows, infrastructure, and equipment as its counterparts in Hollywood, so it's also referred to as "Tlalnewood." Two rooms feature Avid S6 control surfaces, while the other four offer S3s. In addition, every room in the facility includes a JBL speaker system consisting of C211 for the L-C-Rs, 708i for surround speakers and height speakers, JBL465C Subs (two units per room) — four rooms with a full Dolby Atmos 7.2.4 configuration and the remaining two in a 7.2 surround setup.

Focusrite is the number one choice

Focusrite was Malvicino's number one choice, he says. "All the rooms are connected through Dante, which is the key for this project. The clarity of the sound is unbelievable. The ease of installation and the cost savings are mind-boggling. I've been working with Focusrite for such a long time and have done numerous studios over the years with them, so for me it's a no-brainer."

6699

"The clarity of the sound is unbelievable. The ease of installation and the cost savings are mind-boggling... so for me it's a no-brainer."

Horacio Malvicino

Principal of Malvicino Design Group

The RedNet interfaces offer several advantages when it comes to their integration, a factor that not everyone considers, says Malvicino. "The units take up very little space. That's something that people tend to overlook, especially when you do an installation where you have four computers for each room — which already take a lot of space — and you need to leave a space in between them. But Focusrite units are 1U and they don't produce any heat, so you stack them one on top of the other and that's it — done."



Setting up for streaming and Dolby

The new sound facilities are designed to meet the technical requirements of the major streaming services, which are driving the current growth in production in Mexico. "If you're mixing for Netflix, Amazon, Hulu or Apple, you can monitor how it would sound on the platform," Malvicino says.

Malvicino ran the numbers through Dolby's DARDT [Dolby Audio Room Design Tool] software to ensure that the rooms met the Atmos certification specifications. He worked with his regular contractor, TADI [Taller de Arquitectura + Diseño Interior], based in Mexico City, on room construction. "The two architects that run the company are great. They know the way I design and the way I want stuff to get built. We imported a bunch of installation materials from a company called AMC in Spain. We raised the ceiling on the third floor. Having a general contractor that has built studios for me before — they've built more than 15 studios around the world with me over the years — makes the process a lot easier."



Horacio Malvicino, principal of the Malvicino Design Group, handled the acoustic and technical design of the six new rooms (four with a full Dolby Atmos setup), also consulting with the equipment integrator 3BH (3BlueHouse), a professional AV specialist company based in Mexico City.



Two-time Oscar-nominated supervising sound editor and mixer Martin Hernandez heads up sound services at Cinematic Media, which is led by managing director Arturo Sedano. Hernández, who regularly works with director Alejandro G. Iñárritu, was Oscar-nominated for his work on *The Revenant* (for which he also earned a BAFTA) and *Birdman*.



System Racks

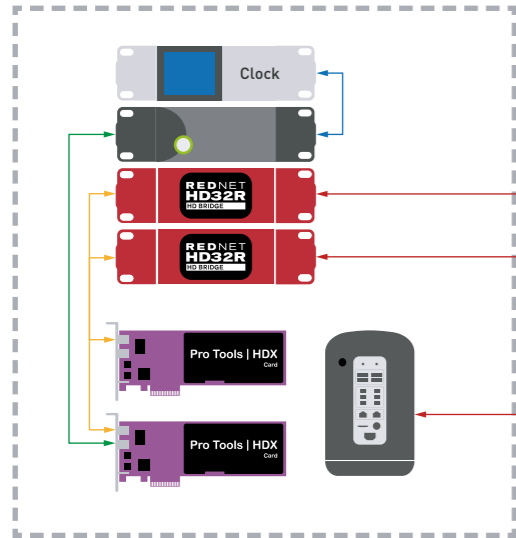

Amp Racks

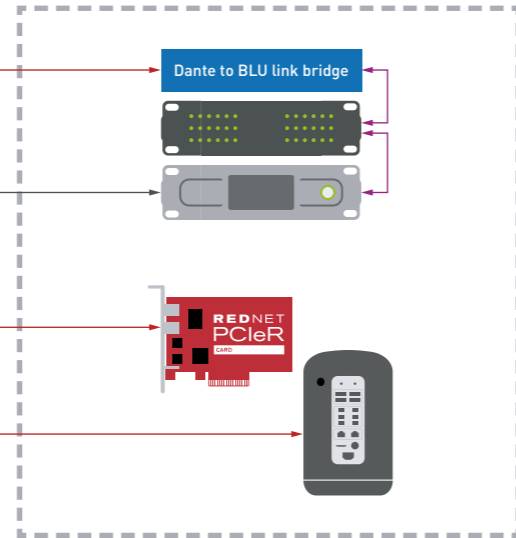

- Dante® Ethernet —
- Control —
- DigiLink —
- Clock —
- BLU Link —
- Analogue —



Mix Studio

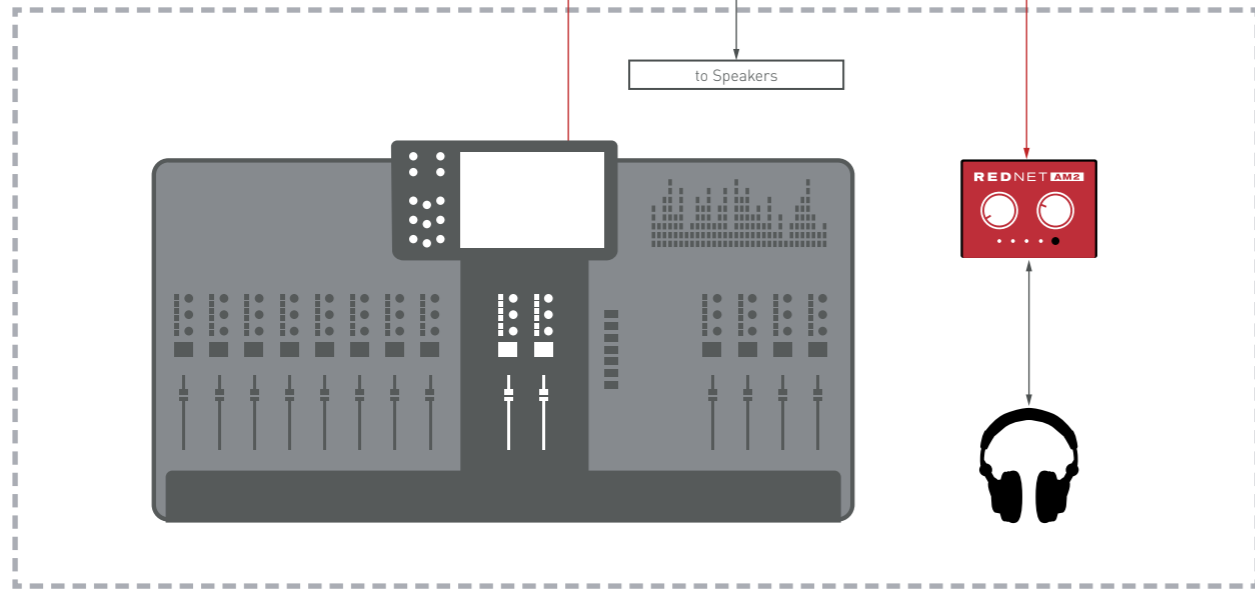

System Racks

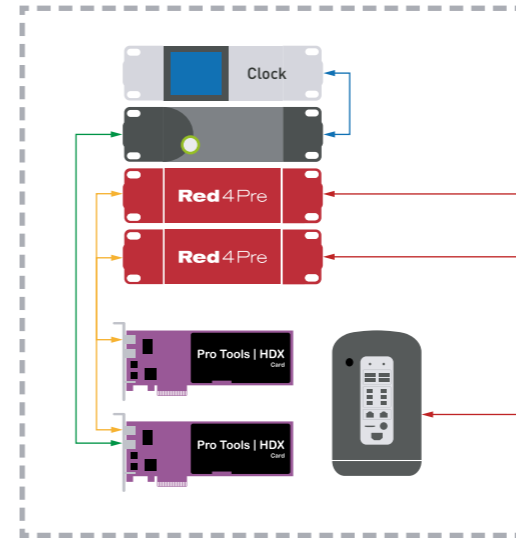

Amp Racks

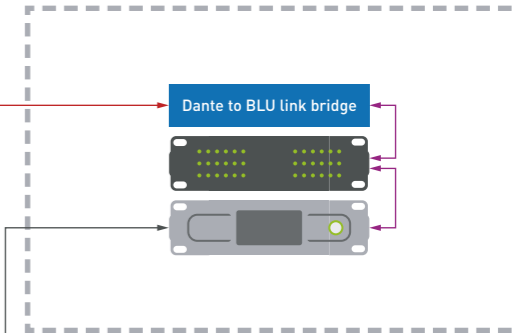

- Dante® Ethernet —
- Control —
- DigiLink —
- Clock —
- BLU Link —
- Analogue —



Mix Studio

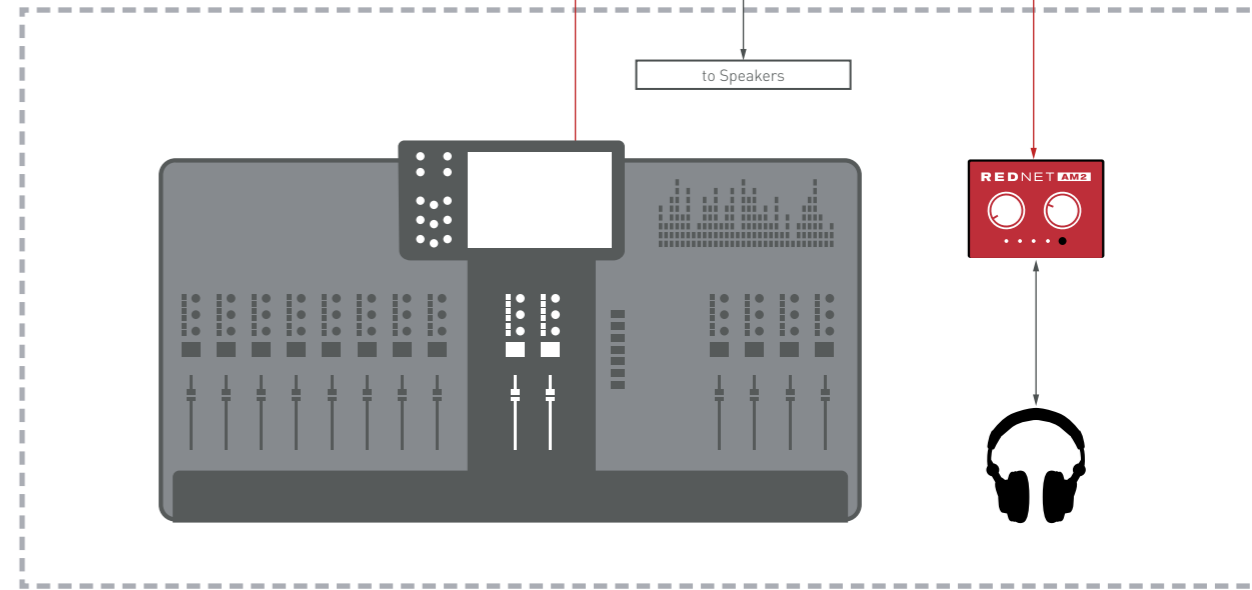

Cinematic Media uses:



4 x RedNet HD32R

32x32 Pro Tools | HD I/O
with dual PSUs



2 x Red 4Pre

58x64 all-in-one interface
32x32 Dante I/O

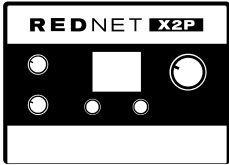

1 x RedNet X2P

2x2 analogue I/O with 2x mic pres,
headphone and line output,
PoE supplied

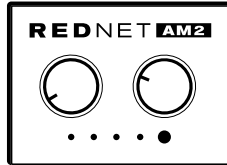

1 x RedNet AM2

Stereo headphone and
line output PoE supplied

About Focusrite Pro

Focusrite Audio Engineering has pioneered professional audio recording technology spanning almost three decades. Focusrite Pro, the company's professional and commercial division, meets the demands of recording, post-production, live sound and broadcast professionals. It consists of RedNet, a fully modular audio-over-IP solution, and the Red range, Focusrite's flagship multi-format interfaces, along with the heritage ISA range of microphone preamplifiers and analogue signal processors. The solutions have been developed to meet the needs of the most demanding applications through a relentless focus on ease of use, quality and reliability. Focusrite is based in High Wycombe, Buckinghamshire, with offices in Los Angeles and Hong Kong.