



REDNET[®]

Kent Hooper

Producer and Engineer Kent
Hooper goes on the road with
Focusrite Pro

**CASE
STUDY**

Focusrite
PRO

On location solutions with Focusrite's RedNet

Words: Diana Smethurst

Kent Hooper is a producer and audio engineer living in Nashville. His credits could fill a book — Amy Grant, Carly Simon, Bill Withers, The London Symphony Orchestra, and many more. He's at home working in his studio, but his real love is being on the road.



"A big part of my work is working for a company called Essential Worship. They do video shoots that happen on location at video and photo studios — we've done probably 20 of these sessions in the last couple of years. Flying (to the location) is always particularly fun and a little tricky because we have to work within the constraints of what you can check in on an airplane, and you have to watch your baggage fees. You're not going to a commercial studio where they just have all the gear and it's all available, so I've got to know exactly how many players, what are they bringing, and I've got to ask dumb questions like 'Are you sure the guitar has a DI?', 'cos it would be bad if it didn't."

Setting up for success

During his time with Essential Worship, Kent's desire to streamline his workflow has meant a radical change in equipment.

"When it first started, they just needed an engineer. We rented a Pro Tools HDX rig, we rented a headphones system — every single thing we rented. After about two of those [sessions] I realised there's got to be a more efficient way, because the set up time was substantial. So Focusrite's kind of changed my world in that way. We bring in my Red 8Line, we bring a rack of Dante® preamps, we've got a headphone system, and we can be completely set up to record anywhere from 2-7 people in the room and we can have levels and be done in a couple of hours."

6699

"So Focusrite's kind of changed my world in that way... we can be completely set up to record anywhere from 2-7 people in the room and we can have levels and be done in a couple of hours."

Kent Hooper

Producer and Engineer



Flexible control with RedNet and Dante

"I have a Focusrite Red 8Line, which is my main Thunderbolt interface and then my laptop. We bring Dante preamps, and we use the RedNet MP8R. It's remote-controllable in a single space which is great for travelling. We have the ISA 828MkII (with an ADN8 card), which is my favourite setting preamp right now, it's just fantastic. Monitoring for these sessions is completely dependent on the space that we're in and because everything is Dante, my only limitation is the length of the Cat 6 cable. So, my control room could be anywhere in the facility, as long as it can reach with the Cat 6.

"Before the RedNet R1, I would have a talkback mic in my makeshift control room to make sure I could talk to the talent and let them know that we're rolling and stuff like that. With the R1, that's got four different talkback routings. So, when we do a shoot now, I've got a talkback to the band with the individual headphone boxes, I've got one routed for the label, I've got a talkback to the video crew and I'm using the R1 as my main headphone amplifier - and it's a really powerful, good-sounding headphone amp."

6699

"What I love about Focusrite is that they're not done. They're not going to quit, like if there's something that they can find a way to do, they're going to do it."

Kent Hooper

Producer and Engineer



Always put the customer first

For Kent, giving customer satisfaction is key. "I'm here to please the client, my job is to make the client happy. If I make the client happy and I make their job easier, they'll keep hiring me. Everything that I've done and bought is all to that end."

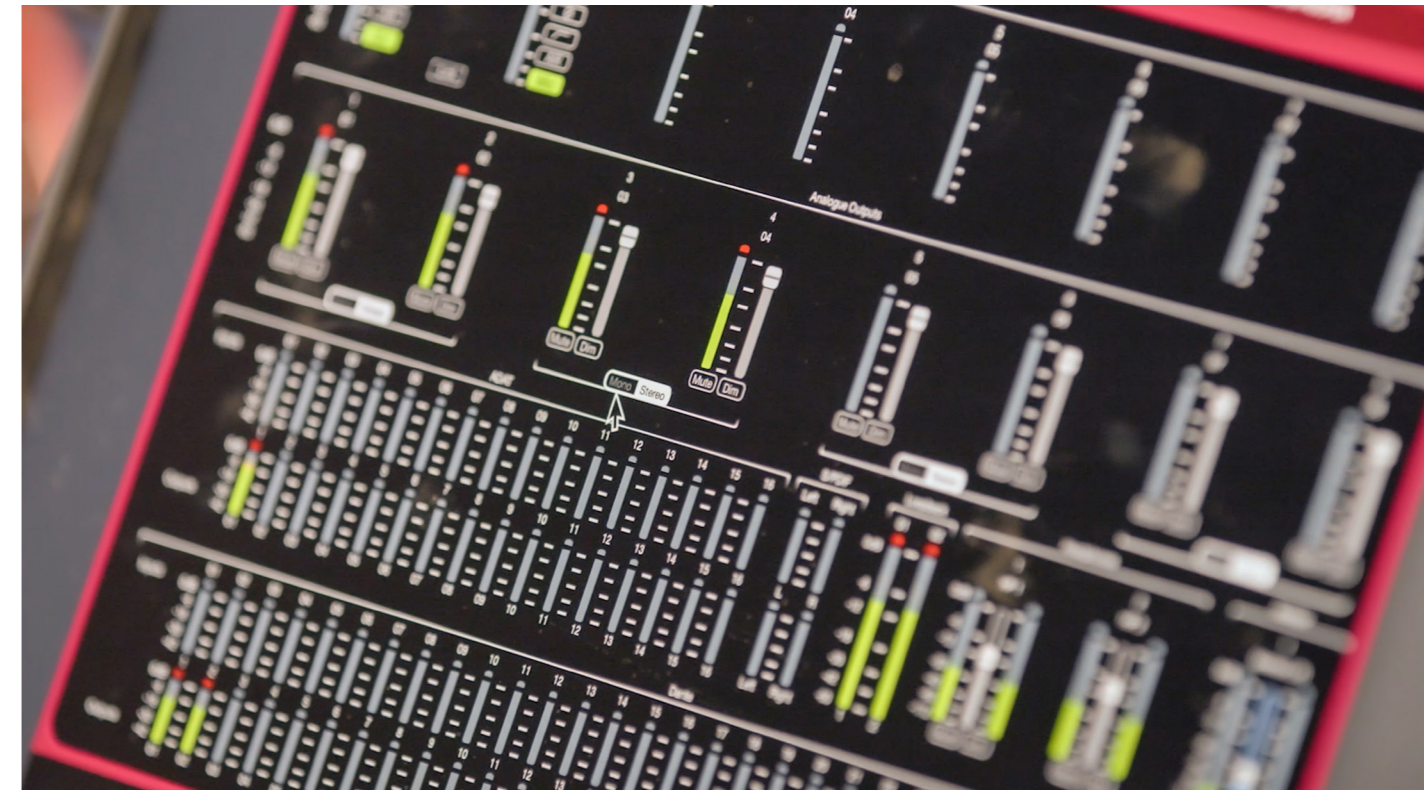

"What I love about Focusrite is that they're not done. They're not going to quit, like if there's something that they can find a way to do, they're going to do it. I just love being involved with a company that's not content. The same way I'm trying to please my client, I feel like Focusrite is trying to do that for their clients."

"The most exciting part for me of these videos is that they truly are live - every single video we've done is 100% live, there's no stacking, there's no overdubs. I might do a little nip and tuck in post, nudging things or if there was a wrong lyric or a bad chord I could grab it from another comp, but it's truly live."

"I still wake up every Monday like just ready to work. I love what I do. I love how the learning never stops. I feel that once you're done learning, it's the time to retire."



Kent Hooper uses:



1 x RedNet MP8R
8-channel remote-controlled mic pre with dual PSUs



1 x Red 8Line
58x64 all-in-one interface
32x32 Dante I/O



1 x ISA 828Mk II
8-channel mic pre and optional A-D card with Dante®

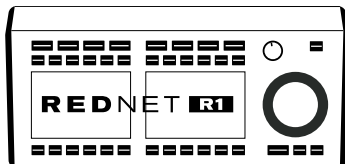

1 x RedNet R1
Desktop Remote Controller

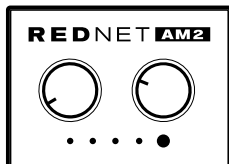

2 x RedNet AM2
Stereo headphone and line output PoE supplied

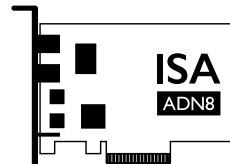

1 x ISA ADN8
8-channel A-D card for ISA 828 MkII, including Dante® connectivity

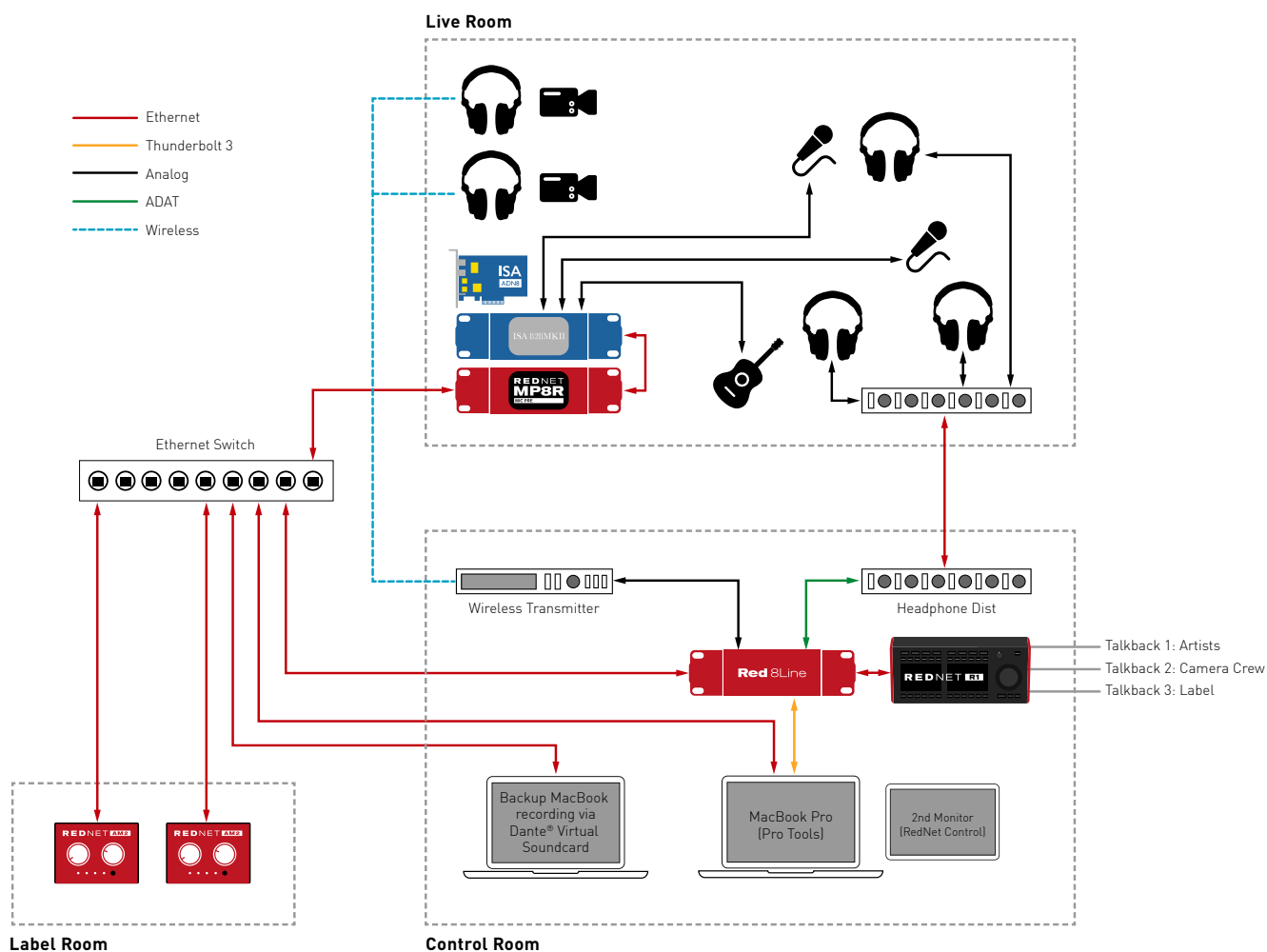

About Focusrite Pro

Focusrite Audio Engineering has pioneered professional audio recording technology spanning almost three decades. Focusrite Pro, the company's professional and commercial division, meets the demands of recording, post-production, live sound and broadcast professionals. It consists of RedNet, a fully modular audio-over-IP solution, and the Red range, Focusrite's flagship multi-format interfaces, along with the heritage ISA range of microphone preamplifiers and analogue signal processors. The solutions have been developed to meet the needs of the most demanding applications through a relentless focus on ease of use, quality and reliability. Focusrite is based in High Wycombe, Buckinghamshire, with offices in Los Angeles and Hong Kong.